

Standard pass through PB06 type

Prevents dust and bacteria from entering during loading and unloading items at various cleanrooms.

- Possible to confirm electromagnetic lock for door and opening / closing the one side of the door by the buzzer and indicator light.
* Excluding EPB type
- Use large window with good visibility and a flat structure with no bumps to prevent dust accumulation.
- Sterilizes inside with a germicidal light.
* Optional extra excluding EPB type.
* Possible to set germicidal light to turn off automatically
- Reduce dust generation by low-dusting hinge.
- HPB model is equipped with a HEPA filter clean-up function to purify inside.
* Automatic turn off setting is available
- Highly airtight door and all SUS spec. for bio-related fields are also available.
- Possible to install EPB in explosion-proof area due to its mechanical interlock spec.



HPB06 type



APB06 type



EPB06 type

HPB06-□□□R (Electromagnetic lock)

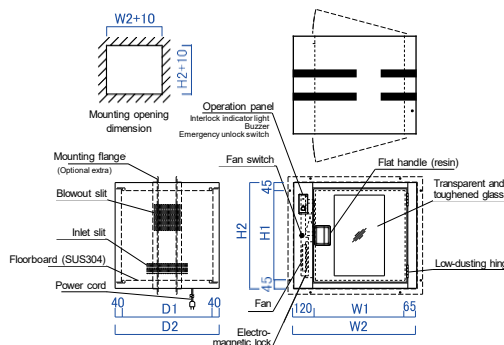

APB06-□□□R (Electromagnetic lock)

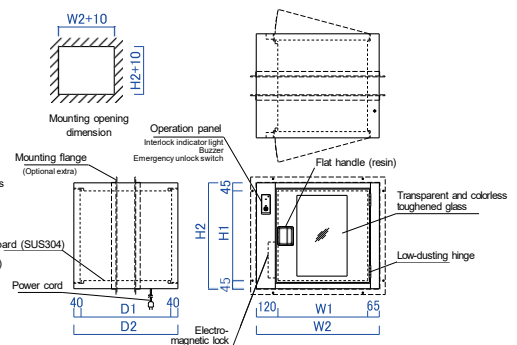

EPB06-□□□R (Mechanical lock)

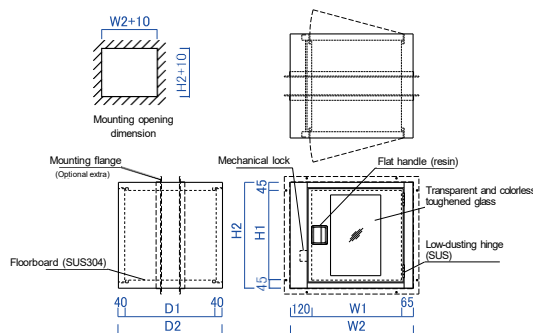

BHPB06-□□□R (Electromagnetic lock)

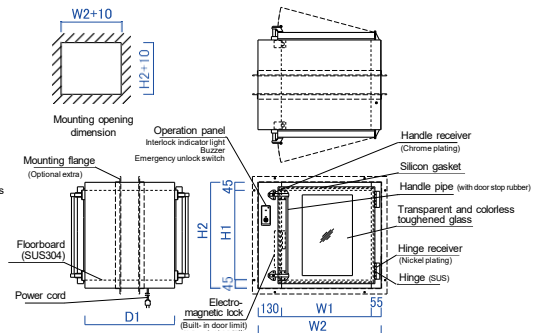

Dimensions by model Unit: mm

Model	W1	W2	H1	H2	D1	D2
□FB06-555R	500	685	500	590	500	580
□FB06-666R	600	785	600	690	600	680
□FB06-777R	750	935	750	840	750	830

Weight by model Unit: kg

Model	Weight	Model	Weight	Model	Weight	Model	Weight
HPB06-555R	55	APB06-555R	50	EPB06-555R	50	BHPB06-555R	60
HPB06-666R	70	APB06-666R	65	EPB06-666R	65	BHPB06-666R	70
HPB06-777R	85	APB06-777R	80	EPB06-777R	80	BHPB06-777R	90

Model	HPB06-□□□R	APB06-□□□	EPB06-□□□R	BHPB06-□□□R
Efficiency	99.99% or higher at 0.3μm particles	—	—	—
Air volume:	Approx. 1m ³ /min	—	—	—
Main filter	HEPA filter ×1	—	—	—
Interlock	Electromagnetic lock	Electromagnetic lock	Mechanical lock	Electromagnetic lock
Power source	AC100V 1φ 50/60 Hz	AC100V 1φ 50/60 Hz	—	AC100V 1φ 50/60 Hz
Apparent power	Approx. 60VA	Approx. 30VA	—	Approx. 30VA
Structure	Main body: steel plate (baking finish), Floor: SUS 304 hairline finish			
Airtight spec.	—	—	—	Door gasket: silicon, Handle: airtight handle Operation panel: with airtight box

* Electromagnetic lock operation: When one side door is "open", the opposite door is "locked" (Door-to-door interlock).

However, the electromagnetic lock is unlocked during a power failure or by an emergency unlock switch.

* Indicator light and buzzer will alert while the electromagnetic lock is activated.