

# Self setting type SS-AS04 type

Self setting type that is easy to assemble.

- Takes 1 hour when assembled by 3 people.
- Can adjust height and width to suit the existing door
- Optional strip plastic curtain is also available.
  - \* Single-sided type: SS-AS04-02CS
  - \* Double-sided type: SS-AS4-02CW

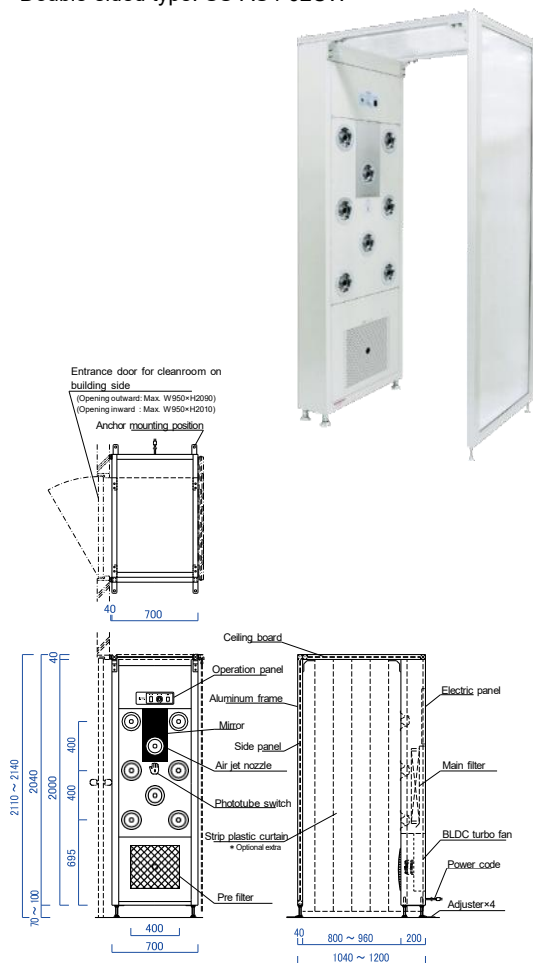

Model	SS-AS04-02
Efficiency	99.99% or higher at 0.3µm particles
Filter element : Main filter	HEPA filter (3A-616150TLAUF)×1
: Pre filter	Saran net (400×350)×1
Air volume:	Approx. 8m³/min (during air jet) * During circulation: Approx. 6m³/min
Blowout air velocity:	Approx. 25 m/s (during air jet)
Air jet nozzle	8 pcs
Noise * at 1m from the device	Approx. 68 dBA
Power source	AC100V 1φ 50/60 Hz
Power consumption :	Approx. 160W (during air jet) * During circulation: Approx. 50W
Apparent power	Approx. 350VA
Blower	LNF-6E×2
Weight	Approx. 150kg
Structure	Main body, side frame: steel plate (baking finish) * Antibacterial coating Ceiling plate, side panel: Hollow polycarbonate board, Floor: none
Optional extra	Strip plastic curtain

# Air shower Double large type

Double large type with a large space, frontage, and depth.

- Large space, frontage, and depth allow for the handling of large items.
- There is a “dolly guard” to protect the inside from the items being brought in.
  - \* Optional extra



Door opening / closing pattern

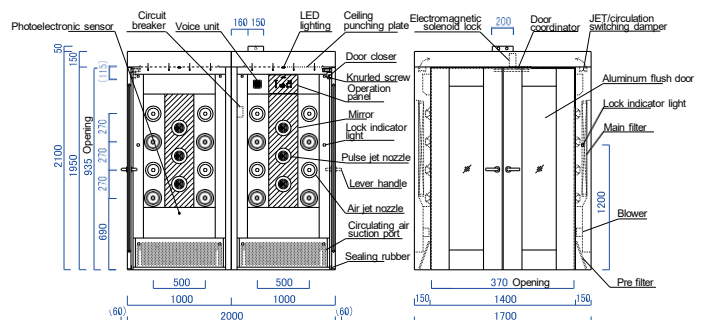
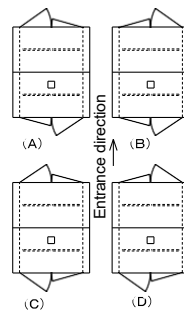

Model	AAS18-1419102APM-R	EAS18-1419102ACM-R
Efficiency	99.99% or higher at 0.3µm particles	
Filter element : Main filter	CD3228464×4	CD3228464×2
: Pre filter	CD3228129×8	CD3228129×4
Air volume: during air jet / circulation (m³/min)	Approx. 47 / 24	Approx. 42 / 12
Blowout air velocity: during air jet	Approx. 25 m/s	Approx. 25 m/s
Air circulation: during air jet / circulation (time/h)	Approx. 516 / 263	Approx. 461 / 161
Air jet nozzle (pulse jet nozzle)	44 pcs (12 pcs)	40 pcs (8 pcs)
Noise * at 1m from the device	Approx. 72 dBA	Approx. 72 dBA
Power source	AC200V 3φ 50/60 Hz	
Power consumption: during air jet / circulation	Approx. 1100W (6.0A) / 190W	Approx. 1270W (6.0A) / 110W
Apparent power	Approx. 2550VA	Approx. 2590VA
Blower	LNF-6G×4	LNF-6G×2
Weight	Approx. 620kg	Approx. 560kg
Structure	Main body: steel plate (baking finish), Floor: none	* Use building floor

\* Main filter is a HEPA filter, and pre filter is a saran net filter.